

Product Guide

User and Maintenance Information

Important Information: Please save this product guide.

Customer Service:

United States

PO Box 2
Ulster Park, NY 12487
Office hours: 9-5 EST
Phone (800) 777-4244
Fax (800) 336-5948
(845) 572-3468

www.CommunityPlaythings.com
Sales@CommunityPlaythings.com



F778 Browser Box

Recommended Use

The "Browser Box" provides a unique, accessible and versatile book display or storage system for infants and toddlers.

⚠ WARNING

- ▲ This product is intended for use by children of immature judgment, therefore supervision is required at all times.

⚠ CAUTION

For indoor use only. The Browser Box is not water-proof.

Assembly

This product comes in one carton completely assembled. The carton contains:

- This Product Guide.
- One 36-3/4" Browser Box.
- Two Sliding Dividers (in Clear Plastic Bin).

If your shipment is incomplete, please call your Community Playthings Customer Center.

Operation

The dividers in the clear bin can slide easily to any position desired. To remove a divider from the bin (e.g.: for cleaning):

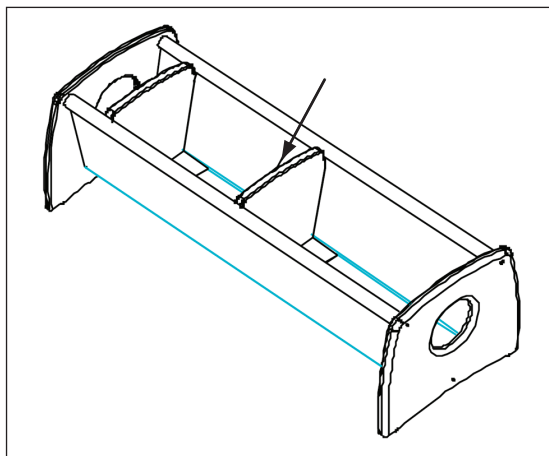

Figure A

A Slide the divider to the center of the bin. (Fig. A)

B Rotate the divider in the bin until it snaps loose. (Fig. B.)

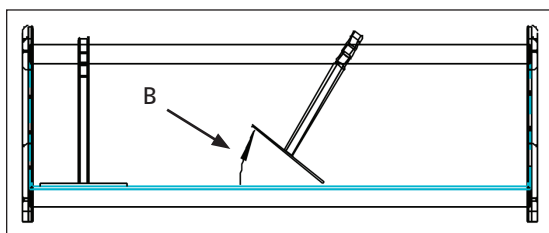

Figure B

Maintenance

Periodically inspect for cracks, breaks, loose parts, missing parts, and/or malfunctions. Remove the product from service when any condition develops that might make operation unsafe.

Cleaning

Wipe the wood parts and clear bin with a damp cloth and a mild detergent. Do not use excessive water.

⚠ CAUTION

- ▲ Do not use organic solvents such as Acetone, or Paint Thinners to clean the clear plastic bin.

Construction

This product is fastened by dado/screw joints. The sides are made from solid maple, finished with a durable clear finish. The dowels are made from sturdy hardwood. The clear bin is made from durable plastic. Construction includes the following features:

- Smooth maple sides provide a broad base for stability.
- The clear plastic bin creates an attractive, highly visible storage area.
- 4-1/2" holes in each end provide excellent hand-grips for moving.
- Solid maple dividers (snapped into the bin) can slide back and forth to create different size compartments.
- The dividers can be removed for cleaning. (See the Operation section below.)

User Modifications

We are not responsible for modifications made by customers to our products in the field without our supervision, testing, or evaluation.

Recycling

The foam pads used in packaging this product are re-useable/recycleable. If you would like to help us preserve the environment, dispose of them appropriately or return them to Community Playthings, US Rt. 40, Farmington PA 15437.

Ordering Parts

To order replacement parts, contact Customer Service with a description of the part(s) needed and the ID Code from the product.

Use only replacement parts supplied by Community Playthings.